

PARTS CATALOG OF

NO. 489 AUTOMATIC FEED

EYELETING MACHINES

CATALOG NO. 489-95



PNEUMATIC



FOOT POWER



ELECTRIC



900 SYLVAN AVE., BAYPORT, NY 11705-1097
(516) 472-2000 • FAX (516) 472-2425

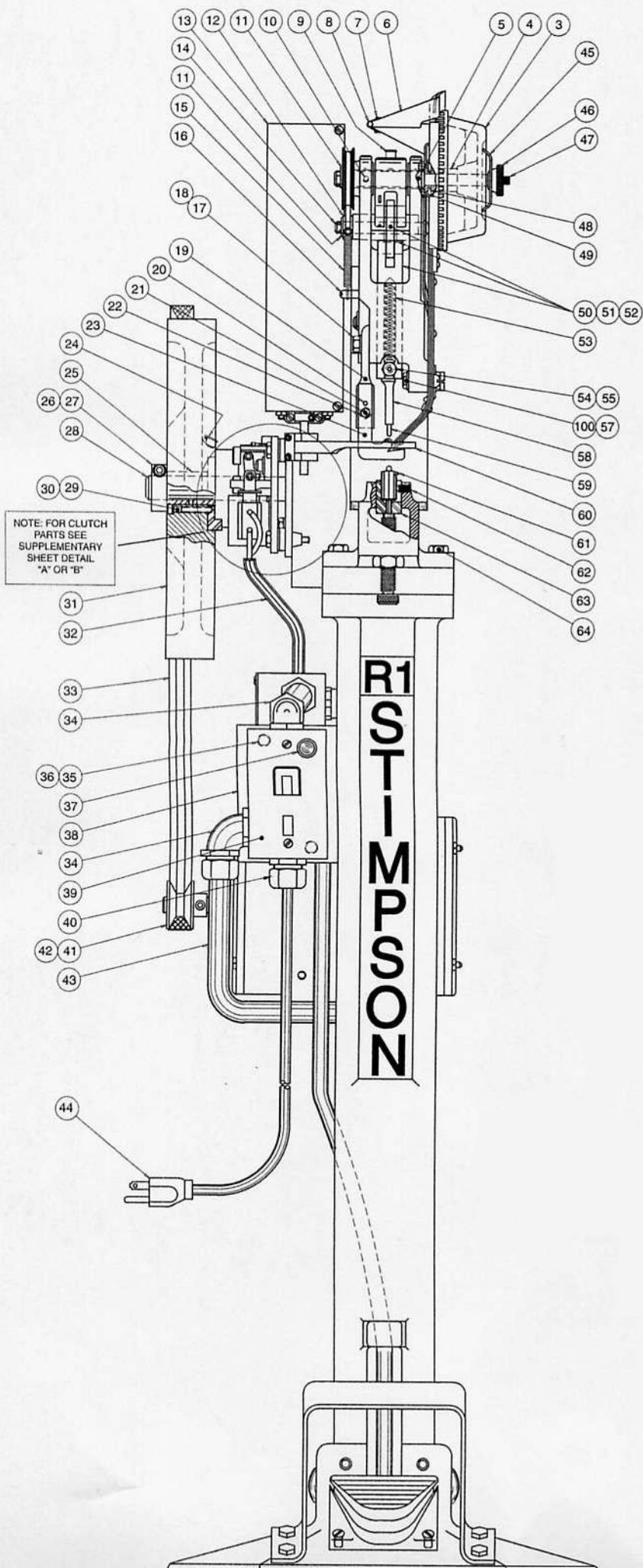

NOTE: SAFETY GUARDS OR OTHER OPERATIONAL SAFETY DEVICES PROVIDED SHOULD NEVER BE REMOVED, DISABLED, OR OVERRIDDEN DURING OPERATION, SINCE THEY ARE DESIGNED TO REDUCE THE POTENTIAL OF INJURY TO OPERATOR.

NOTE: FOR CLUTCH PARTS SEE SUPPLEMENTARY SHEET DETAIL "A" OR "B"

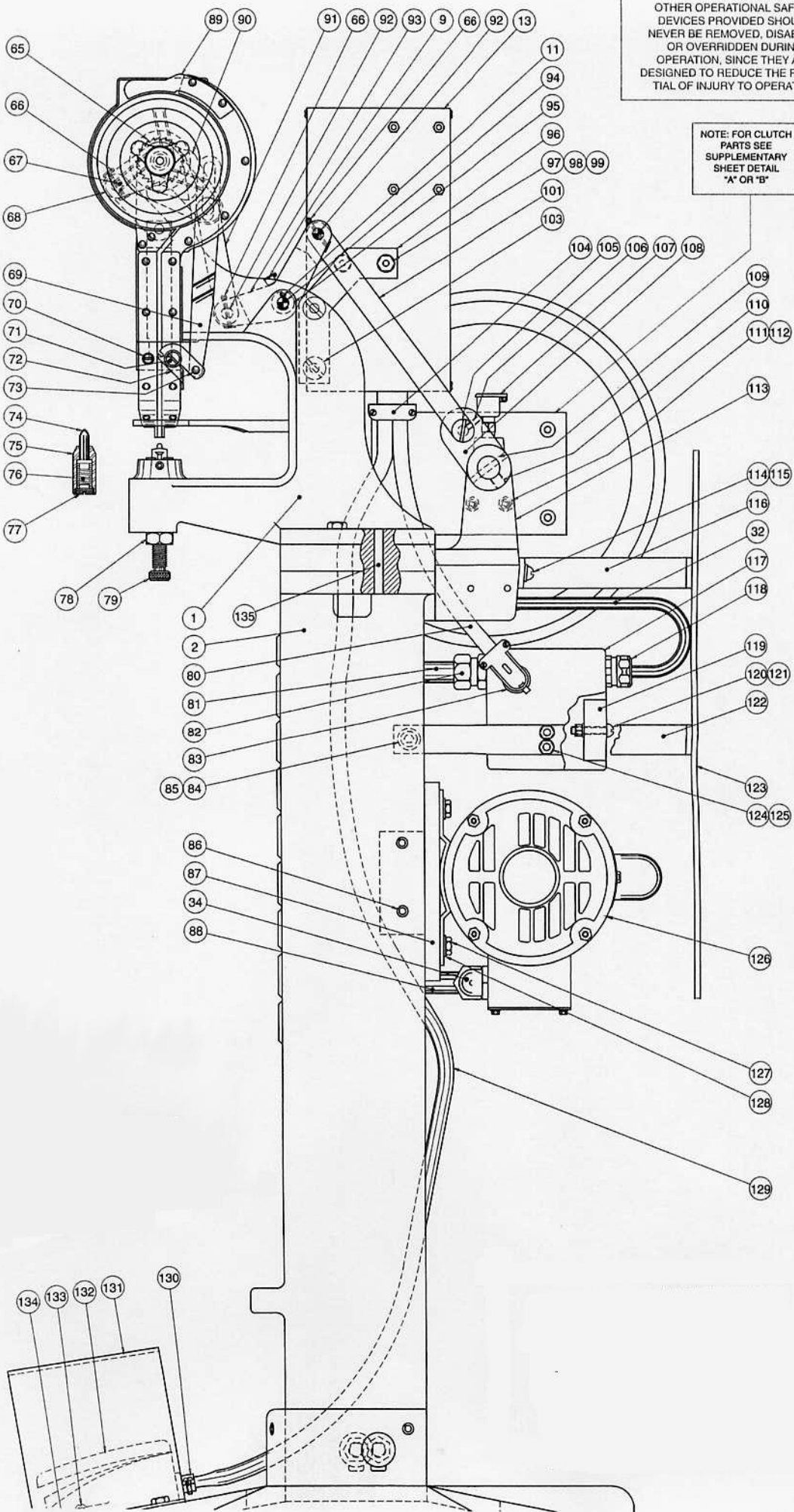

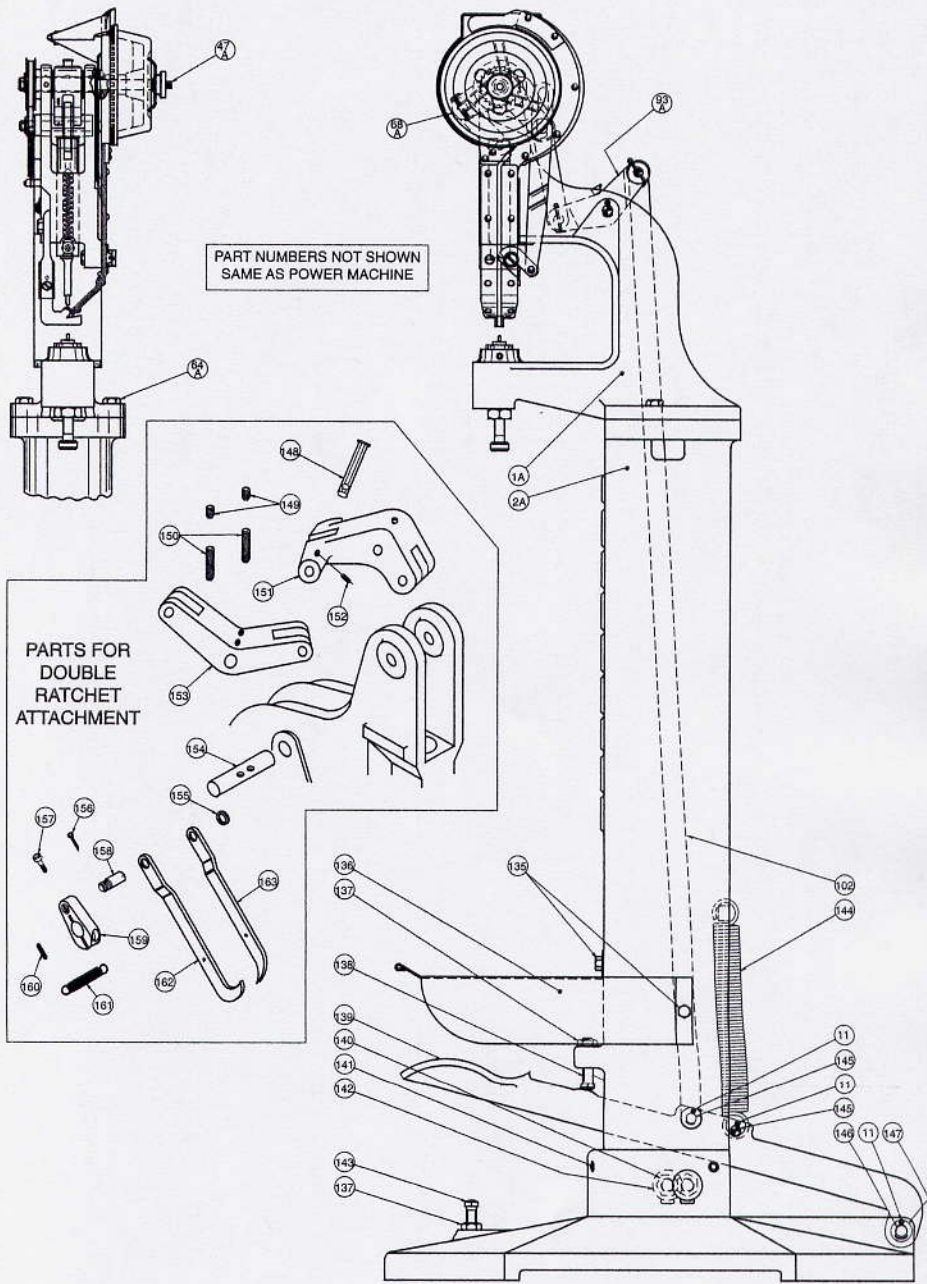

R1
S
T
I
M
P
S
O
N

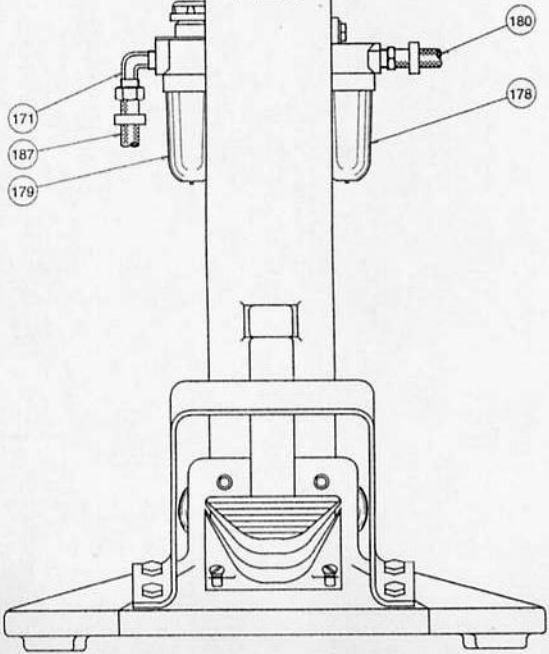

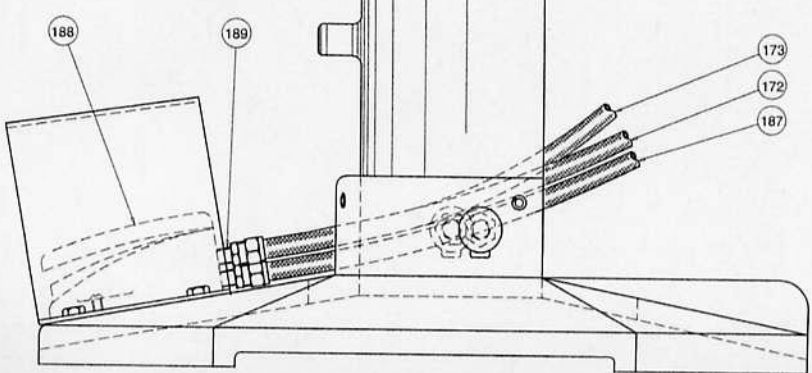
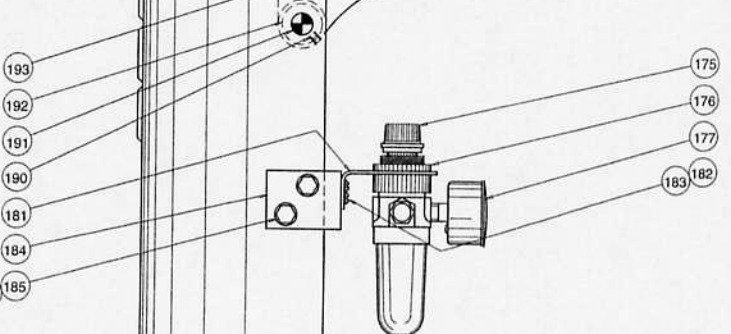
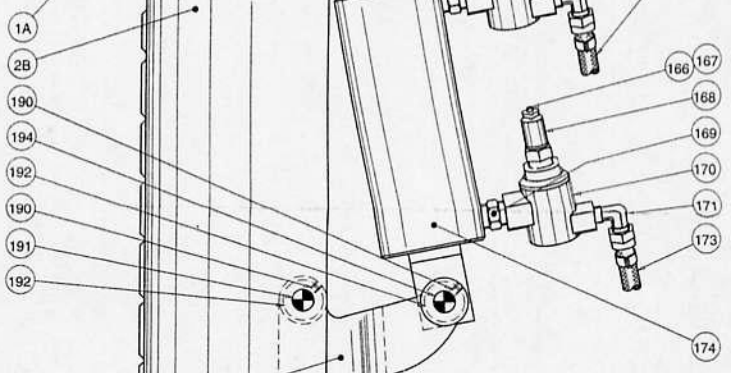
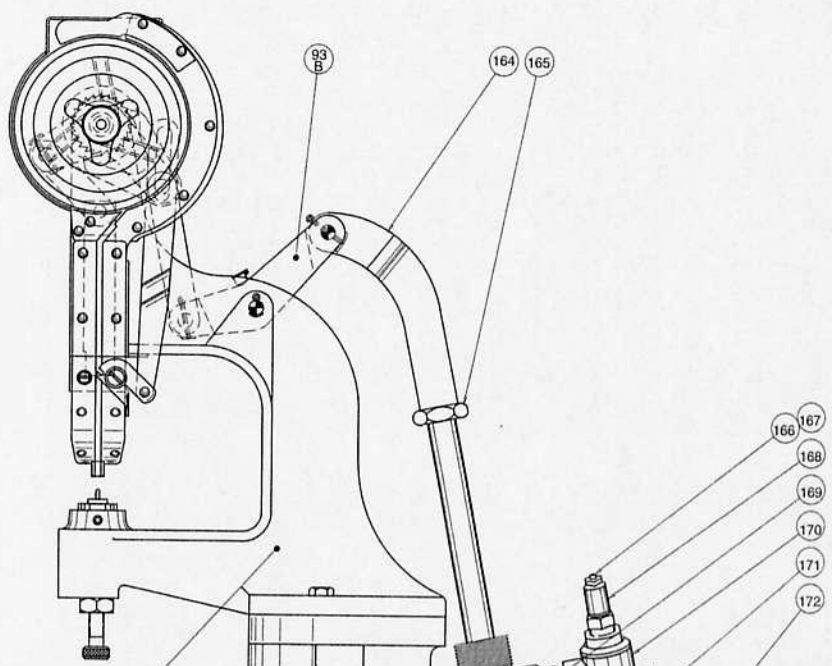

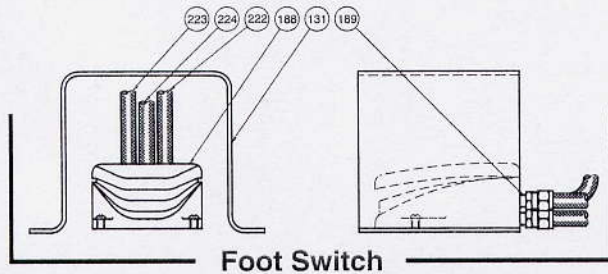
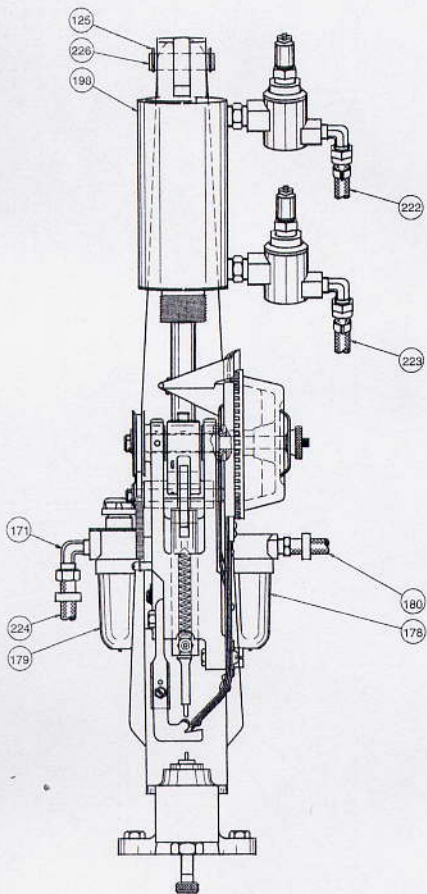

Foot Switch

**PART NUMBERS NOT SHOWN
SEE BENCH PNEUMATIC &
ELECTRIC MACHINE**

NOTE: SAFETY GUARDS OR
OTHER OPERATIONAL SAFETY
DEVICES PROVIDED SHOULD
NEVER BE REMOVED,
DISABLED, OR OVERRIDDEN
DURING OPERATION, SINCE
THEY ARE DESIGNED TO
REDUCE THE POTENTIAL OF
INJURY TO OPERATOR.

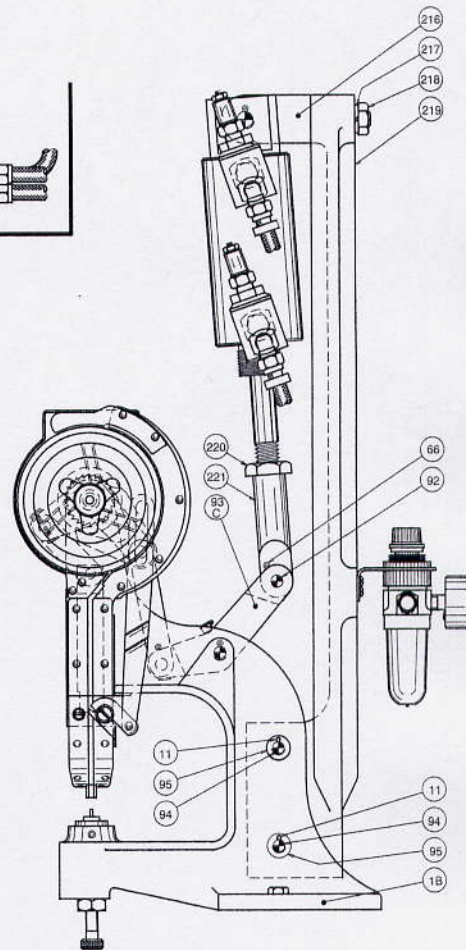

-CAUTION-

TO AVOID INJURY,
HANDS AND FINGERS
MUST BE CLEAR OF
POINT OF OPERATION.

NEVER ATTEMPT TO
ADJUST, REPAIR OR CLEAN
WITHOUT
FIRST DISCONNECTING
POWER FROM ELECTRIC
AND PNEUMATIC MODEL
MACHINES.

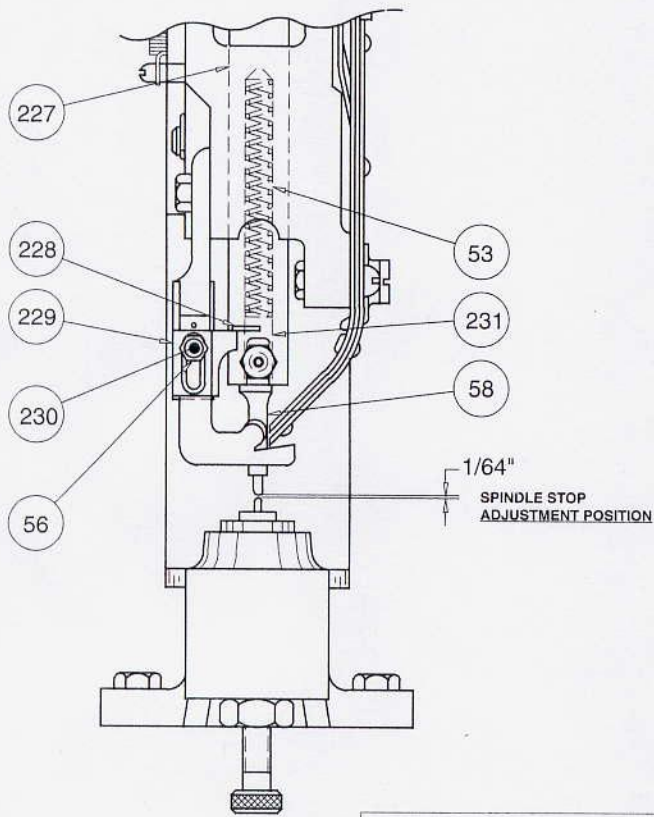

PARTS NUMBERS NOT SHOWN
SEE ELECTRIC MACHINE

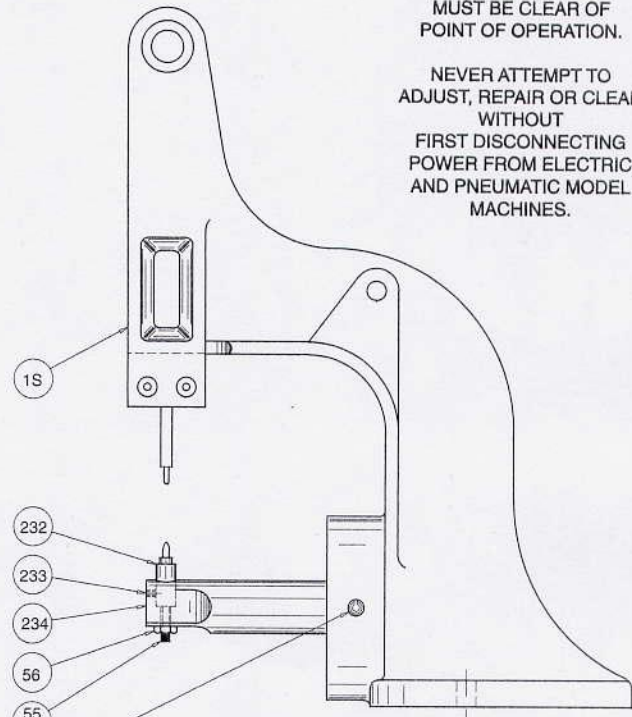

STANDARD STEEL ARM

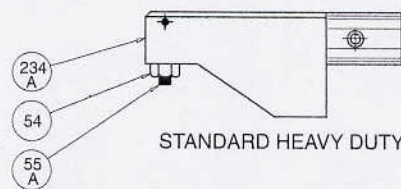

STANDARD HEAVY DUTY STEEL ARM

GUARD FOR ELECTRIC MACHINE

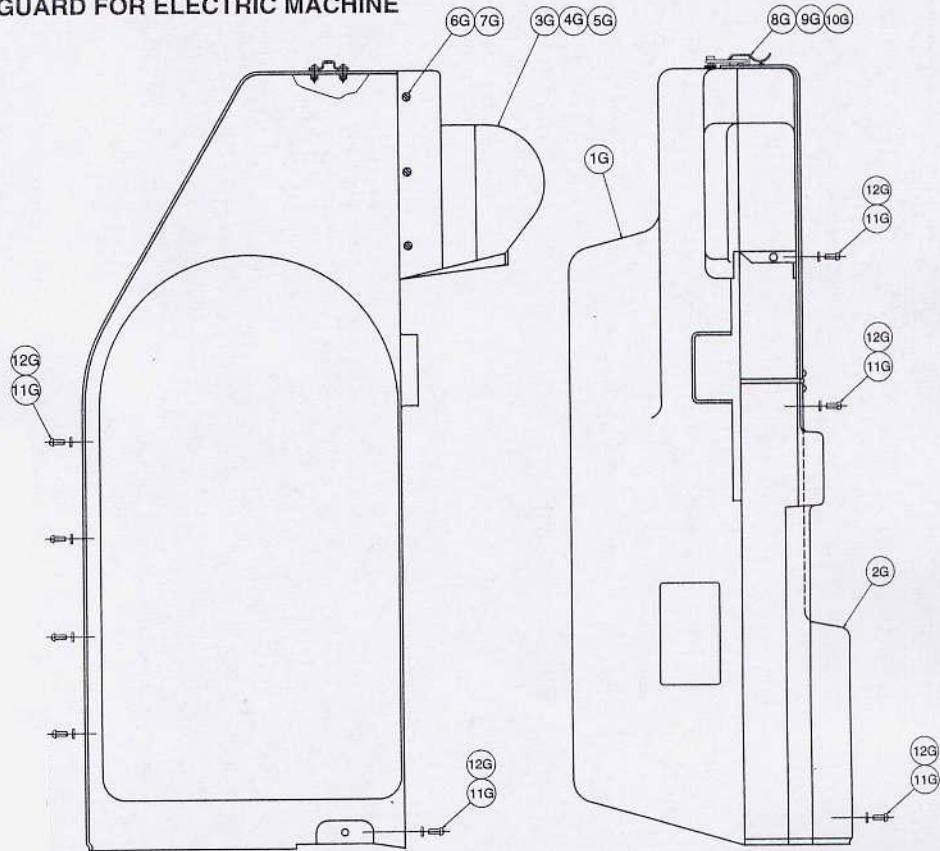

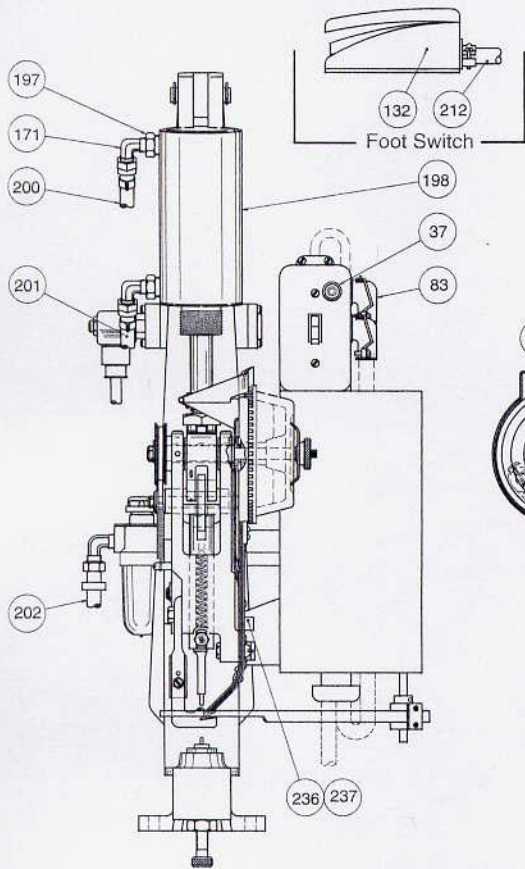

PART NUMBERS NOT SHOWN
SEE BENCH PNEUMATIC &
ELECTRIC MACHINE

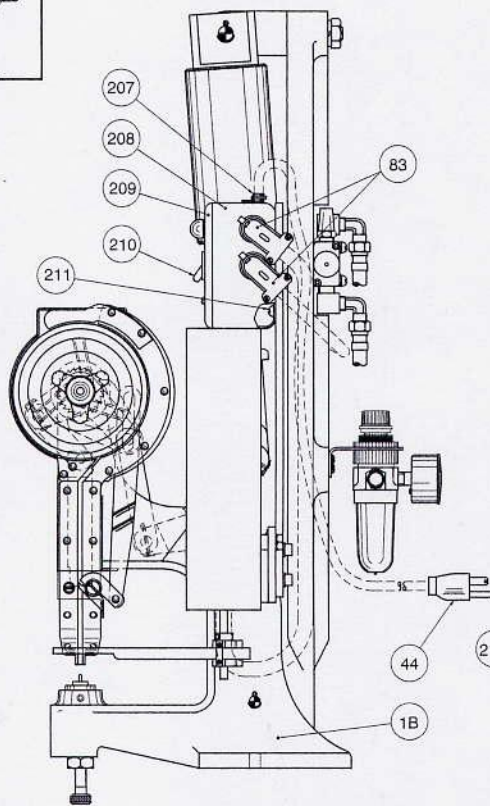

THIS 4-WAY SOLENOID VALVE SET-UP
USED WITH PROTECTO SWITCH ON
BENCH OR STAND PNEUMATIC MACHINE

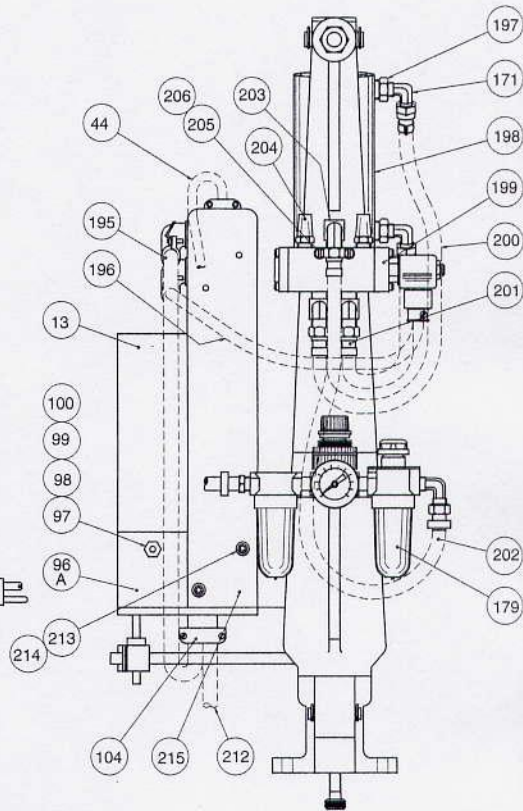

BACK VIEW

Parts List for 489 Machine

1	HEAD FOR ELECTRIC MACHINE
1A	HEAD FOR FOOT PWR. OR STAND PNEU. MACH.
18	HEAD FOR BENCH PNEUMATIC MACHINE
1S	HEAD FOR STEEL ARM
2	STAND FOR POWER MACHINE
2A	STAND FOR FOOT POWER MACHINE
2B	STAND FOR PNEUMATIC MACHINE
3	BOX
4	BOX SPACER
5	BOX STUD BEARING
6	CHUTE COVER
7	4 RIVETS FOR NO. 8
8	CHUTE COVER HINGE
9	OIL CUP (2)
10	SET SCREW FOR NO. 5
11	COTTER PIN (16)
12	WASHER FOR NO. 90
13	PROTECTOSWITCH
14	PAWL PIN
15	PAWL SPRING
16	PAWL SPRING STUD
17	POCKET HOLDER SCREW
18	WASHER FOR NO. 17
19	POCKET HOLDER
20	POCKET SPRING PIN
21	POCKET FASTENING SCREW
22	LOCKNUT FOR NO. 21
23	PAIR OF POCKETS
24	OIL CUP
25	2 BUSHINGS FOR NO. 31
26	SPLIT END COLLAR
27	LOCKSCREW FOR NO. 26
28	MAIN SHAFT
29	FASTENING SCREW FOR NO. 30 FOR FISHER
30	CLUTCH KEY CLUTCH ONLY
31	FLYWHEEL
32	CABLE FOR NO. 117 & CLUTCH SOLENOID
33	BELT
34	CABLE CONNECTOR (3)
35	2 FASTENING SCREW FOR NO. 39
36	2 LOCKNUTS FOR NO. 35
37	RUNNING LIGHT
38	BRACKET FOR NO. 39
39	MAIN SWITCH
40	CABLE CONNECTOR FO NO. 44
41	MOTOR PULLEY
42	LOCKSCREW FOR NO. 41

43	CABLE FOR NO'S 39 & 126
44	POWER CORD
45	BOX SPRING
46	BOX NUT
47	BOX STUD FOR POWER MACHINES
47A	BOX STUD FOR FOOT POWER MACHINE
48	SPACER FOR NO'S 3 & 89
49	SPACER FOR NO'S 1.1A.1B & 89
50	PLUNGER
51	LINK SOLD AS UNIT
52	RIVET
53	SPINDLE SPRING
54	LOCKNUT (2)
55	LOCKSCREW
55A	ANVIL ADJUSTING SCREW FOR NO. 235A
55B	ANVIL ADJUSTING SCREW FOR NO. 235
56	LOCKNUT (3)
57	WASHER FOR NO. 56
58	TOP SET
59	TO SET SPINDLE
60	PROBE
61	BOTTOM SET
62	BOTTOM SET LOCKSCREW
63	BOTTOM SET HOLDER
64	2 HEAD FAST. SCREWS FOR ELECT. MACH.
64A	2 HEAD FAST. SCREWS FOR STAND PN. & P.P.
65	RACHET
66	COTTER PIN (4)
67	HEAD LEVER PLUNGER LINK PIN
68	HEAD LEVER FOR ELECTRIC & PNEU. MACH.
68A	HEAD LEVER FOR FOOT POWER MACH.
69	CUT- OFF LINK
70	CARRIER FASTENING CREW
71	CUT- OFF SCREW
72	CUT- OFF
73	CUT- OFF RIVET
74	RECEDING SPINDLE
75	RECEDING SPINDLE ANVIL
76	RECEDING SPINDLE SPRING
77	RECEDING SPINDLE ANVIL SCREW
78	LOCKNUT FOR NO. 79
79	BOTTOM SET ADJUSTING SCREW
80	CABLE FOR NO'S 13&117
81	CABLE FOR NO'S 39 & 117
82	CABLE CONNECTOR
83	CABLE CONNECTOR (3)
84	FASTENING SCREW FOR NO'S 2, 38 & 122

85	WASHER FOR NO. 84
86	2 ROLL PINS FOR NO'S 2 & 87
87	MOTOR BRACKET
88	CABLE FOR NO'S 39 & 117
89	BOX CARRIER ROADWAY
90	RATCHET PAWL
91	INTERMEDIATE LINK
92	PIN (2)
93	INTERMEDIATE LEVER FOR ELEC. & PNEU. MACH.
93A	INTERMEDIATE LEVER FOR FOOT POWER MACH.
93B	INTERMEDIATE LEVER FOR STAND PNEU. MACH
93C	INTERMEDIATE LEVER FOR BENCH PNEU. MACH.
94	PIN
95	SPACERS
96	MOUNTING BRACKET FOR NO. 13
96A	BRACKET FOR NO'S 13 & 96
97	2 FASTENING SCREWS FOR NO. 96
98	2 LOCKWASHERS FOR NO. 99
99	2 NUTS FOR NO. 97
100	2 SPACERS FOR NO'S 13 & 96
101	CONNECTING ROD FOR ELECTRIC MACHINE
102	CONNECTING ROD FOR NO'S 93A & 139
103	2 FASTENING SCREWS FOR NO. 96
104	CABLE CONNECTOR FOR NO. 13
105	POWER LINK STUD
106	LOCKSCREW FOR NO. 105
107	OIL CUP
108	POWER LINK
109	PIN FOR NO'S 28 & 108
110	LOCKSCREW
111	2 FAST. SCREWS FOR CLUTCH MOUNTING PLATE
112	2 LOCKWASHERS FOR NO. 111
113	POWER BRACKET
114	FASTENING SCREW FOR NO. 116
115	LOCKWASHER FOR NO. 114
116	UPPER BRACKET (UNIT WITH NO'S 122 & 123)
117	CONTROL BOX
118	CABLE CONNECTOR
119	TIME DELAY RELAY
120	SCREW FOR NO'S 117 & 119
121	LOCKNUT FOR NO. 120
122	LOWER BRACKET (UNIT WITH NO'S 116 & 123)
123	BACK BRACKET (UNIT WITH NO'S 116 & 122)
124	2 FASTENING SCREWS FOR NO. 117
125	2 LOCKNUTS FOR NO. 124
126	MOTOR
127	4 FASTENING SCREWS FOR NO. 126

128	4 WASHERS FOR NO. 127
129	CABLE FOR NO'S 13 & 132 (ELEC. MACH.)
130	CABLE CONNECTOR FOR NO'S 129 & 132
131	GUARD FOR NO'S 132 & 188
132	FOOT SWITCH ELECTRIC
133	2 SCREWS W/LOCKWASHERS FOR #S 132 & 188
134	4 SCREWS FOR NO. 131
135	3 SCREWS FOR NO. 136
136	FOOT TREADLE GUARD
137	LOCKNUT (2)
138	TREADLE ADJUSTING SCREW
139	TREADLE
140	2 LOCKNUTS FOR NO. 142
141	4 PINS
142	2 BOLTS FOR NO'S 2,2A OR 2B
143	TREADLE STOP SCREW
144	TREADLE SPRING
145	PIN (2)
146	PIN FOR NO. 139
147	SPACERS FOR NO. 139
148	PAWL PIN
149	2 LOCK SCREWS FOR NO. 150
150	2 SET SCREWS FOR NO. 154
151	HEAD LEVER
152	SET SCREW FOR NO'S 148 & 151
153	INTERMEDIATE LEVER
154	INTERMEDIATE LEVER FULCRUM PIN
156	COTTER PIN FOR NO.158
157	CLAMP SCREW FOR NO'S 154 & 159
158	PAWL STUD
159	PAWL LEVER
160	SET SCREW FOR NO. 158
161	PAWL SPRING
162	LOWER PAWL
163	UPPER PAWL
164	CYLINDER CONNECTING ROD
165	LOCKNUT FOR NO'S 164 & 174
166	ADJUSTING SCREW WITH NO. 168 (2)
167	LOCKNUT FOR NO. 166 (2)
168	MUFFLER WITH NO. 166 (2)
169	HEXAGON NIPPLE (2)
170	QUICK EXHAUST VALVE (2)
171	ELBOW (3)
172	UPPER HOSE FOR NO. 174
173	LOWER HOSE FOR NO. 174
174	AIR CYLINDER FOR STAND PN. MACH.
175	PRESSURE REGULATOR WITH NO. 177
176	LOCKNUT FOR NO. 175
177	GAUGE WITH NO. 175
178	AIR FILTER
179	AIR LUBRICATOR
180	SUPPLY HOSE

181	FIL-REG.-LUB-GAUGE BRACKET
182	2 SCREWS FOR NO. 181
183	2 LOCKWASHERS
184	BRACKET FOR NO. 181
185	2 SCREWS FOR NO. 184
186	2 LOCKWASHERS FOR NO. 185
187	HOSE FOR NO'S 179 & 188
188	FOOT VALVE (4-WAY PNEUMATIC)
189	HEXAGON NIPPLE (3)
190	LOCKSCREW (3)
191	PIN FOR NO. 193 (2)
192	SPACERS
193	AIR CYLINDER BRACKET
194	PIN FOR NO'S 174 & 193
195	CABLE FOR NO'S 13& 208
196	CABLE FOR NO'S 199 & 208
197	REDUCER FOR NO'S 171 & 198 (2)
198	AIR CYLINDER FOR BENCH PNEUMAT
199	4 WAY SOLENOID VALVE
200	UPPER HOSE FOR NO'S 198 & 199
201	LOWER HOSE FOR NO'S 198 & 199
202	HOSE FOR NO'S 179 & 199
203	ELBOW (ROD FLAT)
204	MUFFLER (2)
205	3 FASTENING SCREWS FOR NO.199
206	3 LOCKWASHERS FOR NO. 205
207	CABLE CONNECTOR FOR NO'S 44 & 2
208	ELECTRIC BOX
209	COVER WITH 2 SCREWS FOR NO. 208
210	MAIN SWITCH
211	2 FASTENING SCREWS FOR NO. 208

212	CABLE FOR NO'S 13&132
213	2 FASTENING SCREWS FOR NO'S 96A
214	2 LOCKWASHERS FOR NO. 213
215	BRACKET FOR NO. 208
216	CYLINDER HOLDER
217	LOCKWASHER FOR NO. 218
218	NUT FOR NO. 216
219	CYLINDER BRACKET
220	LOCKNUT FOR NO'S 198 & 221
221	CYLINDER CONNECTING ROD
222	UPPER HOSE FOR BENCH PNEUMATI
223	LOWER HOSE FOR BECH PNEUMATIC
224	HOSE FOR NO'S 179 & 188
225	2 COTTER PINS FOR NO. 226
226	PIN FOR NO. 198
227	PLUNGER UNIT FOR NO. 228
228	STOP PIN
229	SPINDLE STOP
230	CLAMPING SREW FOR NO. 229
231	TOP SET SPINDLE FOR NO. 229
232	SOLID ANVIL
233	ANVIL LOCK SCREW
234	STEEL ARM
234A	HEAVY DUTY STEEL ARM
235	PIN FOR NO. 235 & 235A
236	2 FASTENING SCREWS FOR NO. 96A
237	2 LOCKWASHERS FOR NO. 236