

# EP 900

## Semi-Automatic Attaching Machine

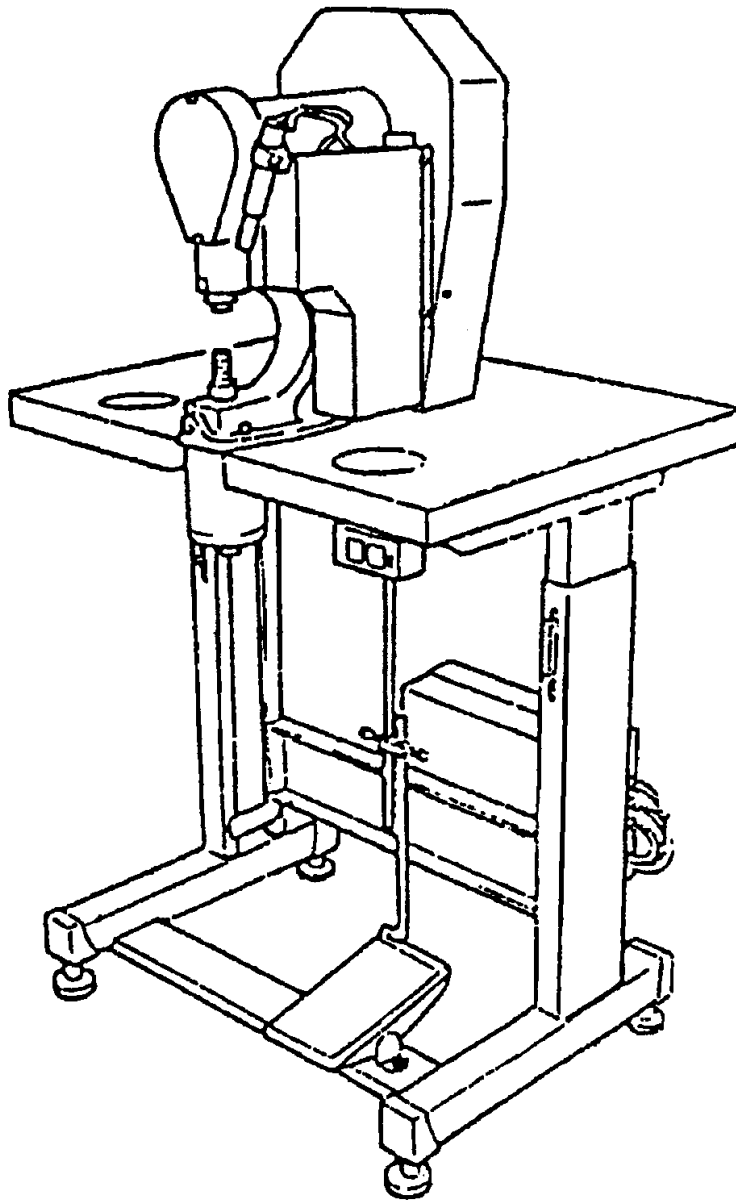

# CONTENTS

SAFETY INSTRUCTIONS .....	3
1. Machine Overview .....	4
2. Control Unit Functions .....	7
3. Operation .....	7
4. Maintenance and Management .....	12
5. Troubleshooting .....	13
6. Electrical Diagram .....	17

# SAFETY INSTRUCTIONS

Observe the instructions below in order to operate the machine safely.

- Before using the equipment, read the operation manual provided for each piece of equipment, so that you use the equipment safely.
- NEVER remove any of the safety devices.
- For safety, NEVER remove any of the covers for the drive unit while working with the machine.
- Warning labels indicating prohibitions and cautions are affixed to the machine and safety devices. Operators should observe the instructions on these labels for their own safety.
- Check that the machine's surroundings are safe before starting up the machine.
- NEVER put your hands between the punch and die while the power is turned on (and especially during startup). The safety devices cannot protect your hands from crushing by the punch and die.
- Stop the machine immediately if you notice anything wrong.
- Install the machine on a firm, level surface that is able to bear its weight. If the machine has casters, lock them after the machine is installed.
- Before connecting the electric cable, check that the power supply is of the specified type.
- Make sure that the machine has been grounded to prevent electrical leakage.
- Be sure to turn off the power before replacing the fixtures, before leaving the machine unattended, and at the end of work.
- For work safety, keep the machine and its surroundings tidy and free of all objects that could obstruct the work.
- Inspect the machine before the start of work and after the end of work, without fail.
- Never modify the machine for any reason. Modifying the machine is hazardous.

## 1. Machine Overview

### 1.1 Features

- No adjustment is needed to allow for fabric thickness. Products can be fitted to any fabric whose thickness is within the range prescribed by Scovill standards, even if same garment has both minimum and maximum thicknesses.
- The height of the lower tool holder is easily adjusted to accommodate almost any size and type of fastener. This allows the setting pinch to be changed quickly and accurately when different attaching tools are used.
- Simple structure facilitates maintenance, minimizes troubles and makes for greater safety.
- Motor-powered machine is operated by a pedal, freeing hands for other work. (Double-tripping prevention mechanism provided.)
- The fitting unit is equipped with safety devices, letting operators feel safe as they work.
- A target light for more accurate positioning is optionally available.

**NOTE: Do not use the machine for any purpose other than that for which it is intended.**

### 1.2 Products (fittings)

- The machine is ideal for fitting jeans buttons, jeans rivets, snap buttons, and snappets, etc.
- For details, see the product catalog.

Included with each machine is a set of five hex head socket wrenches: 3mm, 5mm, 6mm, 8mm, and 12mm.

- The 3mm wrench fits the set screws that hold the upper and lower attaching tools in the holders. It also fits the two set screws that allow the height and position of the lower safety ring to be adjusted.
- The 5mm wrench fits the screw located on the front of the compensator spring housing. This screw locks the lower tool holder in the correct position once the setting pinch has been adjusted.
- The 6mm wrench fits the two screws that hold the compensator housing to the head of the machine, below the lower die holder.
- The 8mm wrench fits the screw that adjusts the height of the lower tool holder.

- The 12mm wrench adjusts the tension on the compensator spring

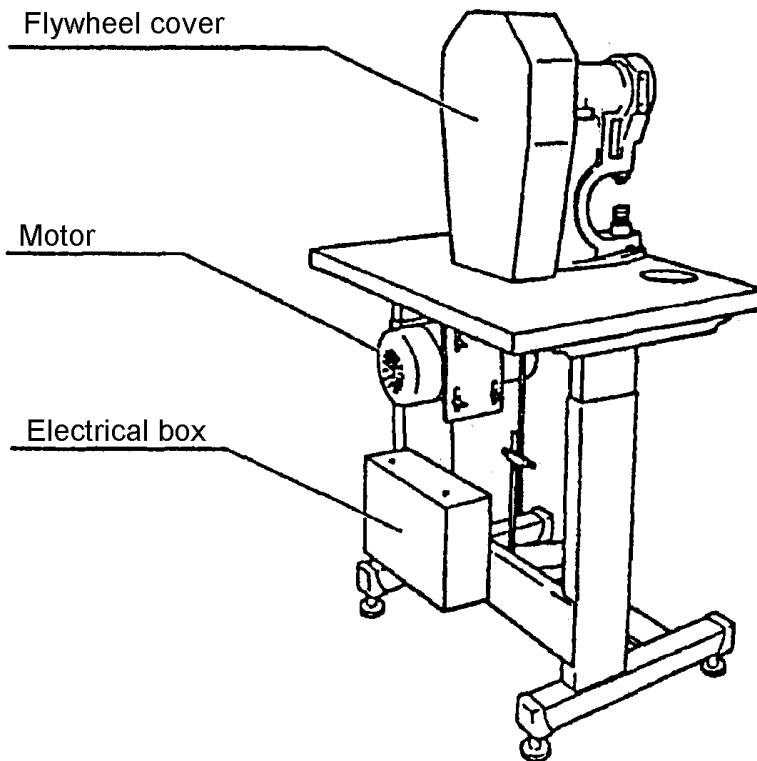
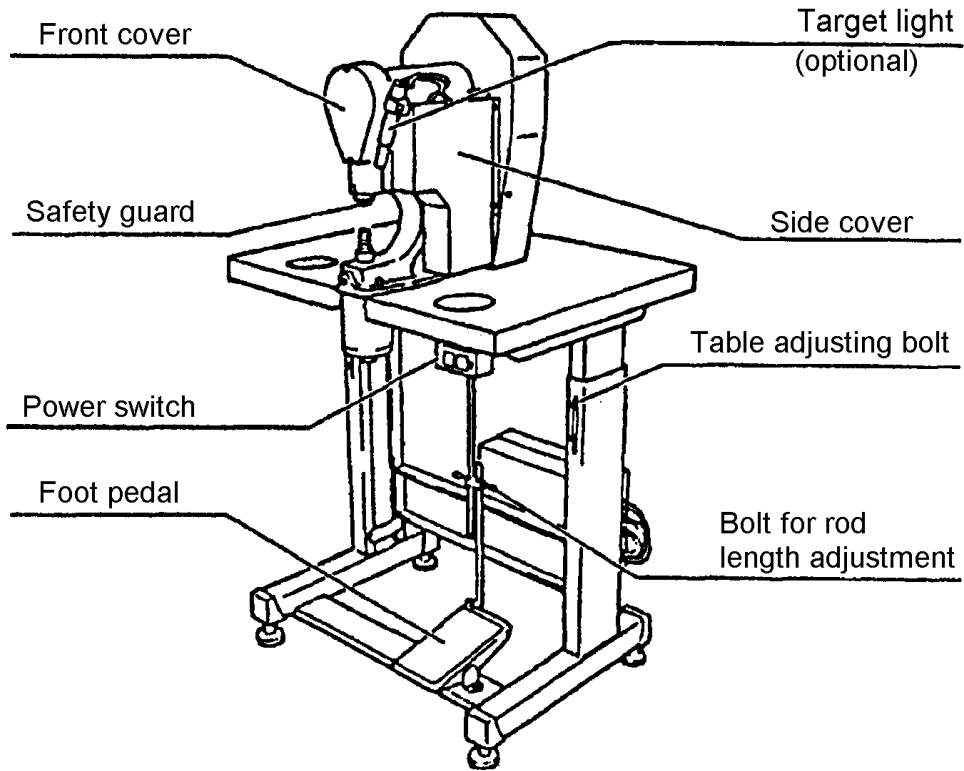

## 1.4 Machine specifications

### 1. Machine dimensions

Width	700mm
Depth	550mm
Height	1,190-1,240mm (adjustable)

### 2. Machine weight

NET	78kg
-----	------

### 3. Power source

250W single phase motor

### 4. Capacity

0.2 sec per cycle

Actual production: 3,000 pieces / 8 hours

## 1.5 Equipment

### 1. Accessories (standard tools)

- Bar wrench (3,4) 1 of each Total 2
- Fuses 2

### 2. Options

- Laser Light projector unit
- Hook and eye unit

## 2. Control Unit Functions

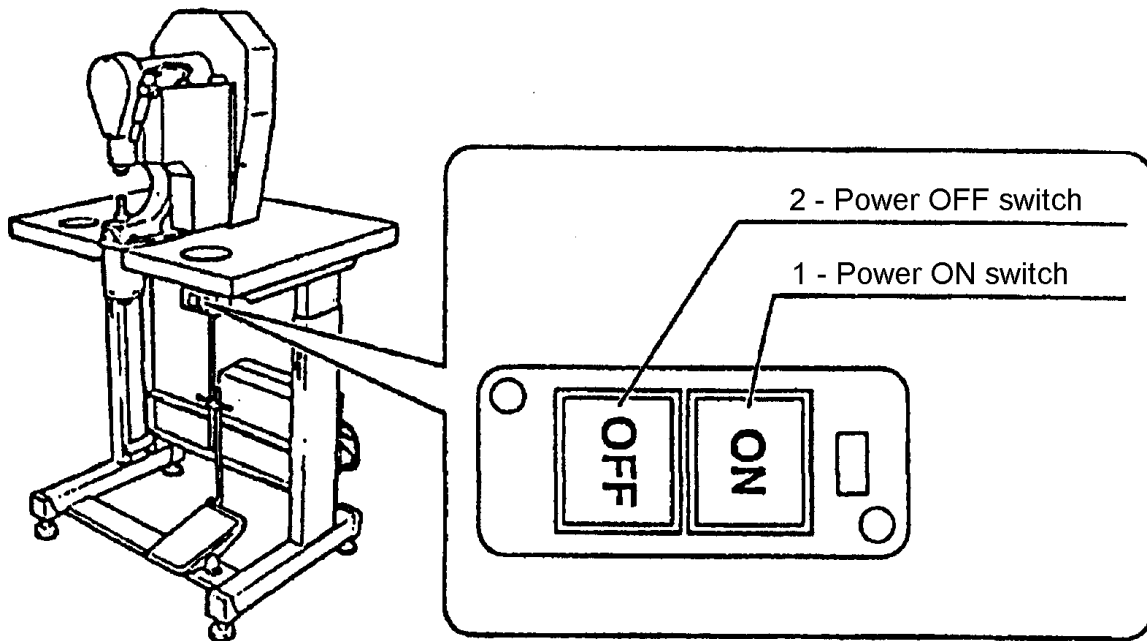

NO.	Name	Function
1	ON	Turns on the power, starting up the motor. Also turns on the target light (optional). Power is turned off automatically if over-current occurs.
2	OFF	Turns off the power, stopping the motor.

## 3. Operation

### \*\*\*CAUTION\*\*\*

Be sure to turn off the power at the end of work, before replacing the fixtures, before leaving the machine unattended, and before repairing the machine.

For safety, be sure to install the side cover over the drive unit and the flywheel cover before working with the machine.

While the motor is running, NEVER put your finger(s) between the punch and die with the foot pedal depressed. Should the safety devices malfunction, your fingers could be injured.

### 3.1 Operation procedure

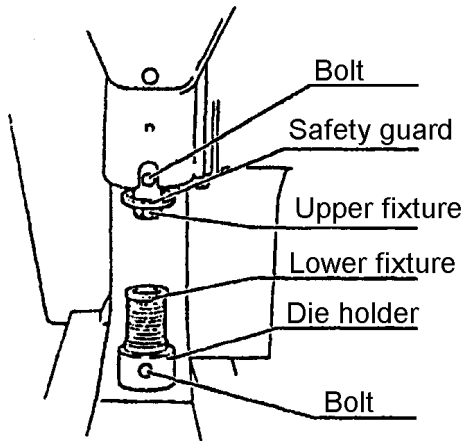

1) Check that the machine is connected to the power supply.

2) Fasten the upper fixture in place with the bolt

3) Set the lower fixture in place. There is no need to fasten it with the bolt.

**NOTE: However, if the lower fixture has orientation, fasten it in place with the bolt. Also fasten a lower fixture for hooks and eyes with the bolt.**

4) Turn on the power. The motor will run, and the target light (optional) will project light.

5) Install the product to the upper fixture and lower fixture.

6) Set the fabric in place. Make sure that it is in the correct position.

7) Depress the pedal. The safety cover will descend, and the fitting operation will be executed. However, if a foreign object is

sensed below the punch, the punch will not descend.

8) Repeat steps 5 through 7 above as many times as necessary to perform the fitting work.

**NOTE: Before starting the fitting work proper, it is recommended to perform a test punching to check work safely.**

### 3.2 Replacing the fixtures

1) Turn off the power.

2) Loosen the upper fixture bolt, and remove the fixture by pulling it out downwards,

3) Remove the lower fixture by putting it out upwards.

4) Install the fixtures for the next product by performing steps 2 and 3 above in reverse.

5) Make necessary pinch setting adjustments. Fitting work can now proceed.



**NOTE: When replacing the lower fixture, check that there are no fasteners or foreign objects inside the die holder.**

### 3.3) Adjusting the Setting Pinch and Compensator (refer to diagram below)

#### Adjusting the Setting Pinch

- Turn the main power switch OFF.
- Install the upper and lower attaching tools as described in section 3.2.
- Load a fastener onto each attaching tool. Trip the machine to make an attachment, and check it to see if the setting pinch is correct.
- Loosen the locking screw “A”. Insert the 8mm wrench up through the bottom of the compensator housing as indicated in diagram. Turn the wrench clockwise to lower the die holder and reduce the setting pinch. Turn the wrench counter clockwise to raise the lower die holder and increase the setting pinch.
- Make several small adjustments to the height of the lower tool holder until the setting pinch is correct. Tighten the locking screw “A”.

#### Adjusting the Tension on the Compensator Spring

The compensator assembly is designed so that there is no need to re-adjust the setting pinch for different thicknesses of material after installing a set of attaching tools. You must be sure that the measured thickness of the material is within the MINIMUM and MAXIMUM limits of the fastener being used. The compensator is set at the factory to work correctly for most situations. If for any reason the compensator must be re-set, the following procedure should be used.

1. Loosen the set screw “B”.
2. Insert the 12mm wrench into the large compensator adjusting screw on the bottom of the compensator housing as indicated in diagram below.
3. Turn the wrench counter clockwise until the compensator spring is fully compressed.
4. Make attachments on the MINIMUM material thickness until the correct setting pinch is achieved.
5. Using the 12mm wrench, turn the compensator adjusting screw clockwise about 2 full turns to begin to allow it to move.
6. Make one attachment on the MAXIMUM material thickness, and determine if the setting pinch is too tight.
7. If the setting pinch is too tight, repeat steps 5 and 6 until the setting pinch is correct.

8. Finally, make another attachment on the MINIMUM material thickness, and verify that the setting pinch is still correct.

**NOTE:** If the correct setting pinch cannot be obtained on both the minimum and maximum material thicknesses, contact your nearest Scovill representative for assistance.

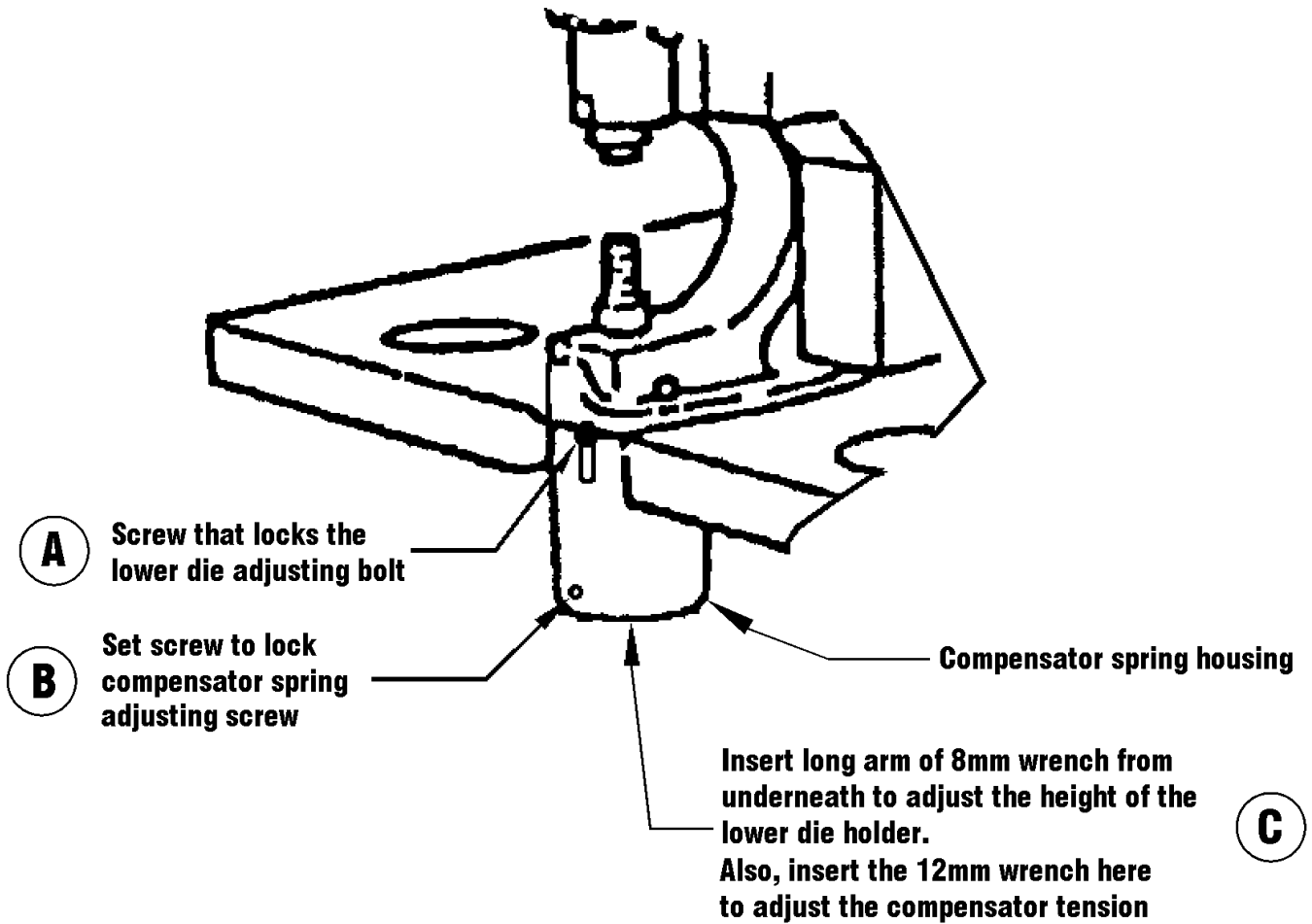

### 3.4) Adjusting the table's height

The table's height can be adjusted within a range of 50mm. Follow the procedure below to carry out the adjustment.

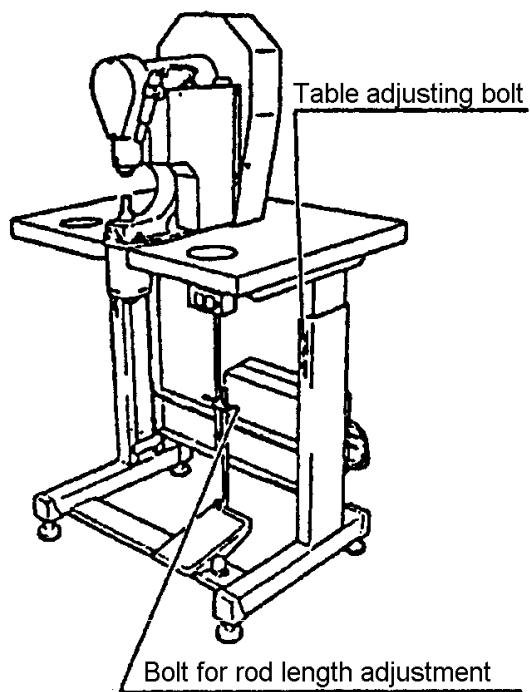

**NOTE: When the table adjusting bolts are loosened, the table descends by its own weight. Therefore, this adjustment work should be performed by 2 or 3 persons together.**

1) Loosen the bolt for rod length adjustment. Then loosen the 8 adjusting bolts of the table's legs, and adjust the table's height.

2) When adjustment is complete, retighten the table leg adjusting bolts. Retighten the bolt for rod length adjustment.

### 3.5) Adjusting the position of the target light (optional)

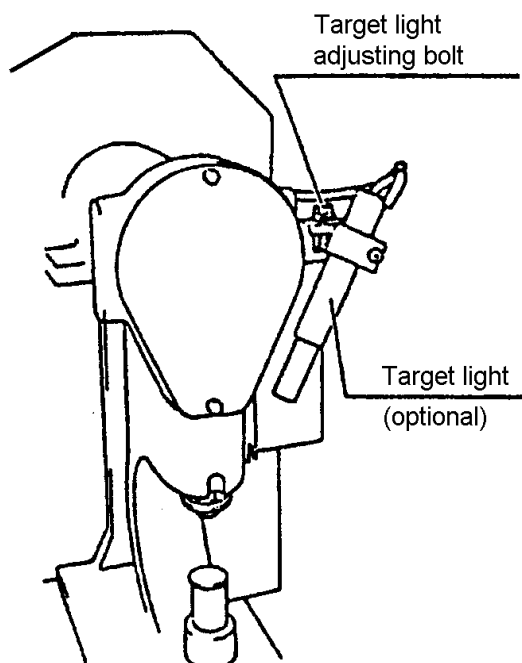

1) Loosen the target light adjusting bolt(s).

2) Position the fabric to which the products are to be fitted, and adjust the target light's position so that the cross mark is over the fitting position.

3) Retighten the target light adjusting bolt(s) to secure the target light in position.

**NOTE: Before starting the fitting work proper. It is recommended to mark a test piece of fabric and perform fitting on it to check that the position is correct.**

## 4. Maintenance and Management

### 4.1) Periodic inspection

Once every month, inspect the following for wear, abnormal noise, and looseness of bolts and nuts: the sliding rotating and connection parts, the electrical equipment, and other pertinent components.

### 4.2) Lubrication

Lubricate the parts below once per month. For the lubricating oil, use machine oil (90# approx.).

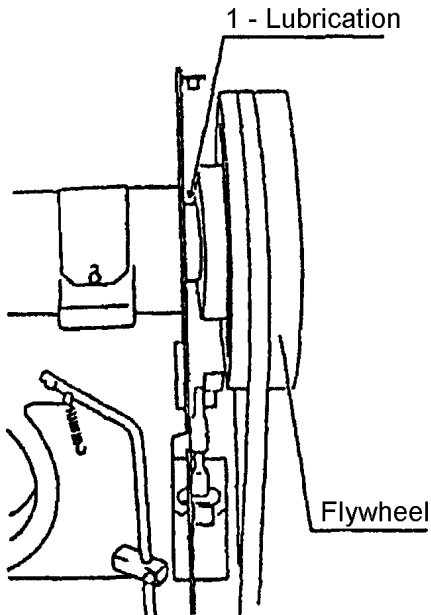

1) Remove the flywheel cover, and then apply 4 or 5 drops of oil to the shaft via the top of the clutch unit, while slowly rotating the shaft by hand.

2) Remove the front cover, rotate the flywheel by hand, and stop it in the position where the oiling hole in the ram's pin portion becomes visible. Then apply 2 or 3 drops of oil through the hole.

3) Apply 2 or 3 drops of oil through the ram's front oiling hole.

4) Remove the die holder. Then apply some lubricating oil to a cloth, and wipe the oil onto the die holder's sliding surfaces with the cloth.

**NOTE: To prevent dirt from adhering to the products, wipe away any surplus lubricating oil and any oil adhering to the fitting unit and its surroundings.**

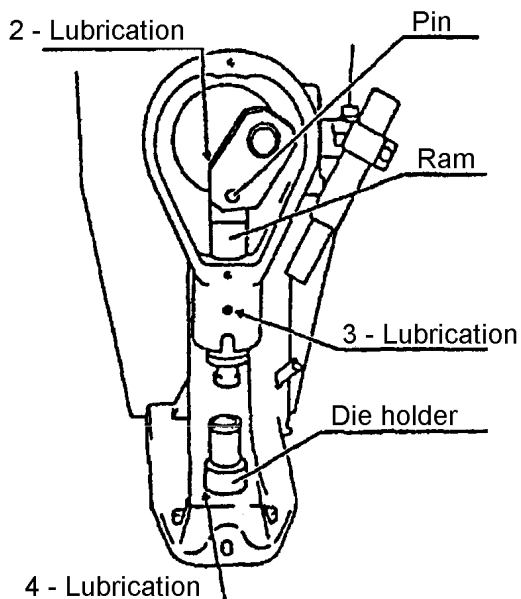

Trouble	Cause	Action
1. Motor does not rotate.	1) Plug is disconnected.	Connect plug.
	2) Power is not turned on.	Turn on power.
	3) Thermal relay inside electrical box has tripped.	Press the thermal relay Manual Reset button.
	4) Fuse is blown.	Replace with spare fuse.
	5) Terminal inside electrical box is loose or disconnected.	Connect terminal securely.
	6) Power input voltage has dropped.	Measure voltage, if possible, and contact inquiry address.
	7) If none of 1 through 6 is applicable, motor is probably faulty.	Contact inquiry address.
2. Punch does not descend when pedal is depressed.	1) Motor does not rotate.	Refer to 1 above.

### 5. Troubleshooting

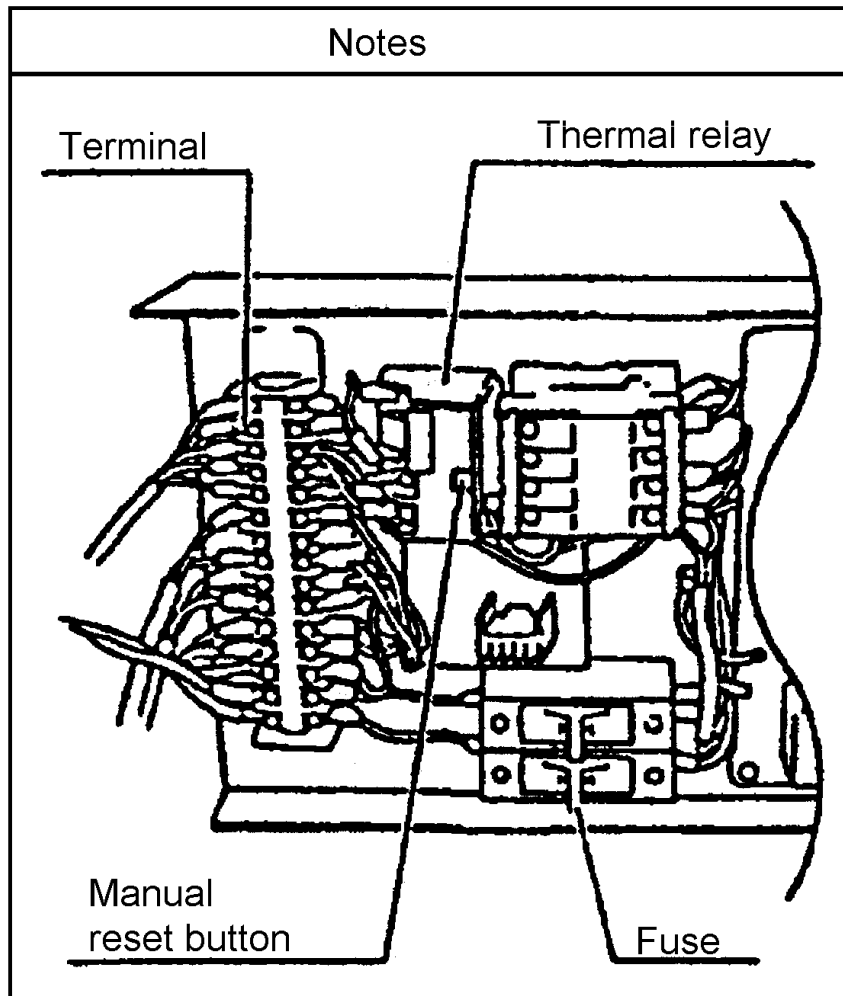

## 5. Troubleshooting (cont)

Trouble	Cause	Action
2. Punch does not descend when pedal is depressed.	2) Safety guard is in contact with fabric.	Adjust safety guard's position. Adjustment procedure: Remove side cover, loosen guard fixing bolts, and lift up guard. Recommended clearance between fabric and guard is 1 mm. <b>CAUTION</b> Do not lift the guard too high. An over-high guard position is hazardous.
	3) Clutch unit part (s) damaged.	Remove side cover and check parts. Contact inquiry address if damage is found.
3. Upper punch stops (near to bottom dead center) in the middle of fitting.	1) V-belt is loose.	Tension V-belt appropriately. Tensioning procedure: 1) Loosen the motor set bolt, and move the motor downward. 2) Make sure the belt is taut. Then securely tighten the bolt.
	2) Overload is caused by fabric thickness outside prescribed range.	Immediately stop motor, and eliminate overload. Overload elimination procedure: 1) Turn off the power, remove the flywheel cover. 2) Using the bar wrench, rotate the shaft in the reverse direction (clockwise) to raise the punch, and then take out the fabric.

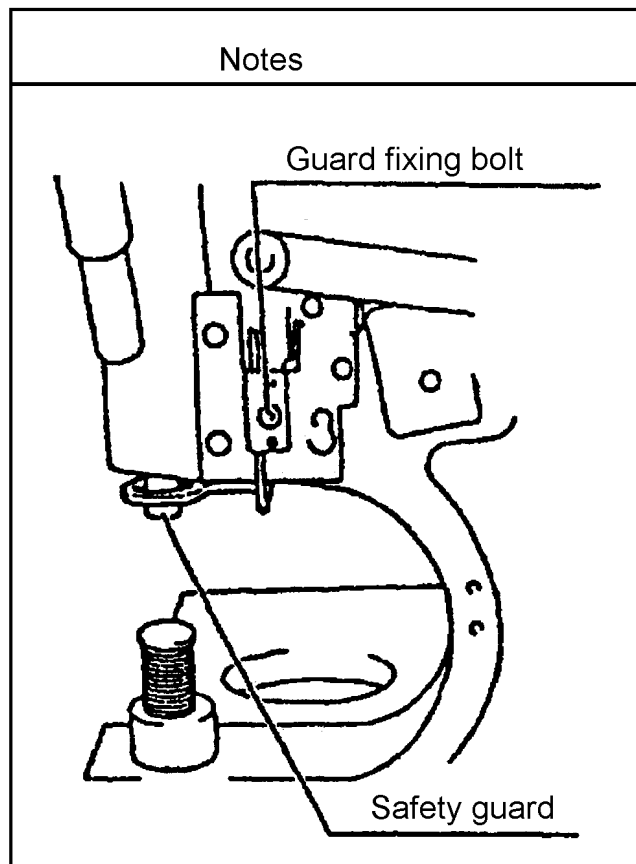

## 5. Troubleshooting (cont)

Trouble	Cause	Action
		<p>3). Rotate the flywheel in the regular direction (Counter clockwise) by hand, until it is in the normal position.</p> <p>4). Turn on the power, and check that the motor runs. If it does not, perform the following:</p> <p>Thermal relay inside the electrical box may have tripped due to overload. Reset the relay.</p> <p><b>CAUTION</b> If fabric thickness is outside of the prescribed range, contact the inquiry address.</p>
4. Light projector (option) does not project light.	1) Power is not turned on.	Turn on power.
	2) Power connector is disconnected.	Properly insert connector.
	3) Lamp's bulb is dead.	Replace bulb. If no spare available, contact inquiry address.

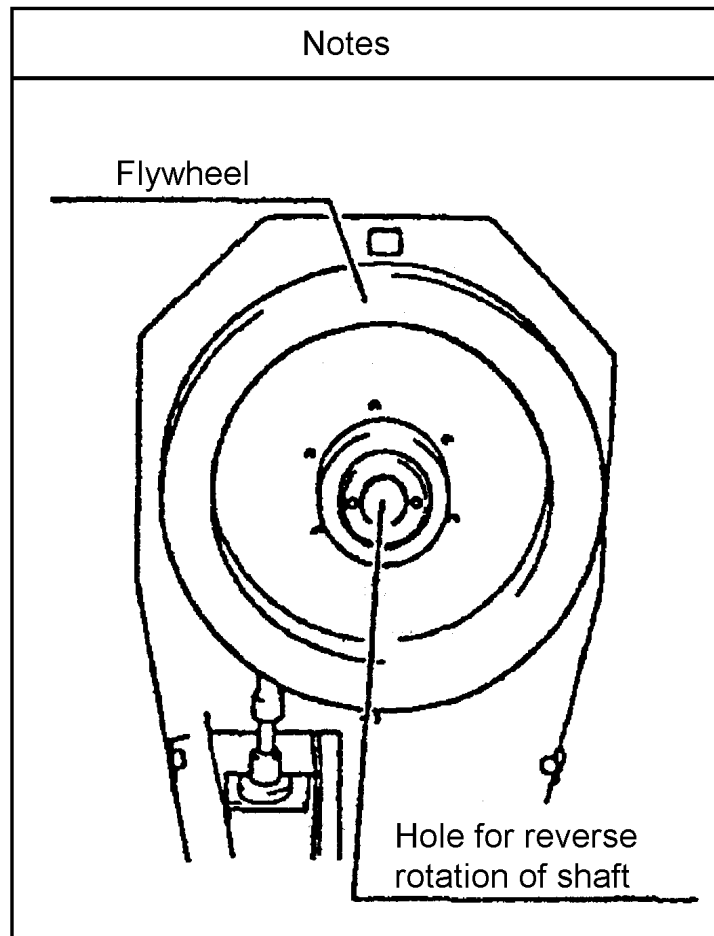

Wiring for Microswitches attached to head of Machine.

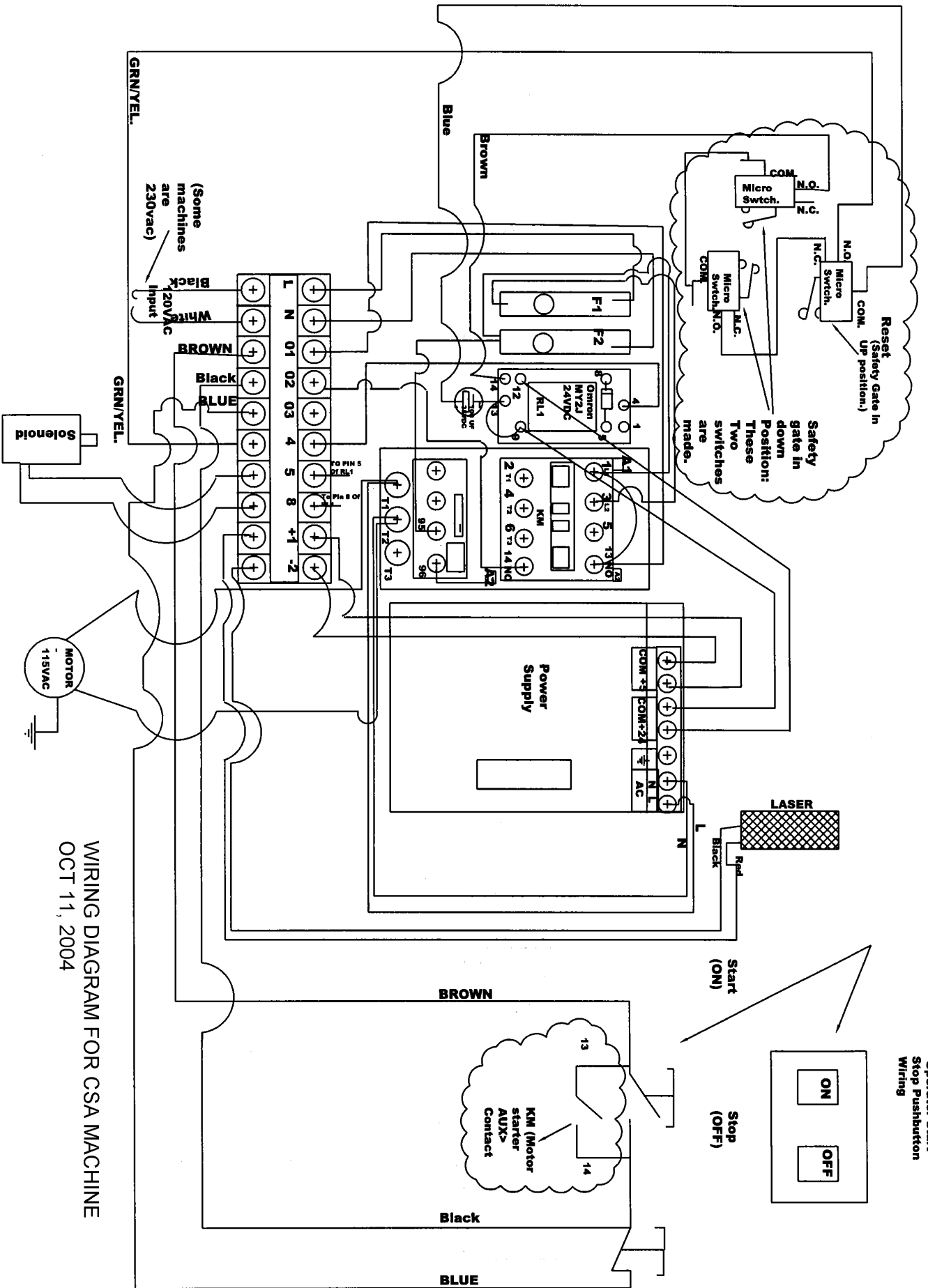

WIRING DIAGRAM FOR CSA MACHINE  
OCT 11, 2004

Operator Start -  
Stop Pushbutton  
Wiring

